

NAPKIN DISPOSAL

- Contemporary Series – Satin Finish
- Concealed Hinge and Lock
- Model 4737 – Recessed **Bradlex™**
- Model 4737-10 – Semi-recessed (recesses 2-1/8"; projects 2")
- Model 4737-11 – Surface Mounted (projects 4-1/8")

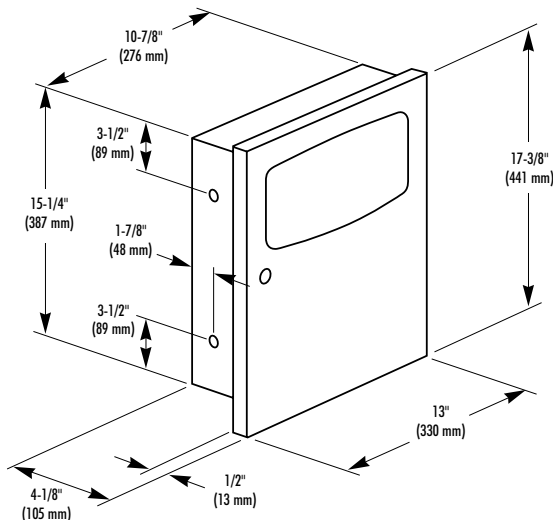

CONSTRUCTION:

- **CABINET** fabricated of type 304 (18-8), 22 gauge stainless steel with exposed surfaces in architectural satin finish. Welded construction with burr-free edges.
- **DOOR** fabricated of type 304 (18-8), 18 gauge stainless steel. 1/2" return for maximum rigidity. Concealed full length stainless steel piano hinge and tumbler lock.
- **PUSH FLAP DOOR** fabricated of type 304 (18-8), 22 gauge stainless steel with exposed surfaces in architectural satin finish. Heavy duty stainless steel piano hinge.
- **WASTE RECEPTACLE INSERT** fabricated of heavy gauge stainless steel. All welded construction.

CAPACITY:

1.5 gal. (.2 cu. ft.)

OPERATION:

Waste container removable by unlocking cabinet door. Furnished with waxed paper liner.

INSTALLATION:

Recessed unit requires rough wall opening 11-3/8"W x 15-3/4"H x 4"D (Semi-recessed unit only 2-1/8" deep). Top of wall opening 2'-9" above finished floor. Secure to framing with mounting screws (included) at holes provided. Shim at screw points as required.

GUIDE SPECIFICATION:

Recessed napkin disposal shall be fabricated of type 304 (18-8), stainless steel with exposed surfaces in satin finish. Door with full length concealed piano hinge and lock. Self-closing push flap door secured by piano hinge. Removable stainless steel receptacle.

Overall dimensions: 13"W x 17-3/4"H x 4-1/8"D.

Recessed Napkin Disposal shall be Bradley Model 4737.