

# NAPKIN DISPOSAL

□ Model 4731-15 – Recessed **Bradlex™**

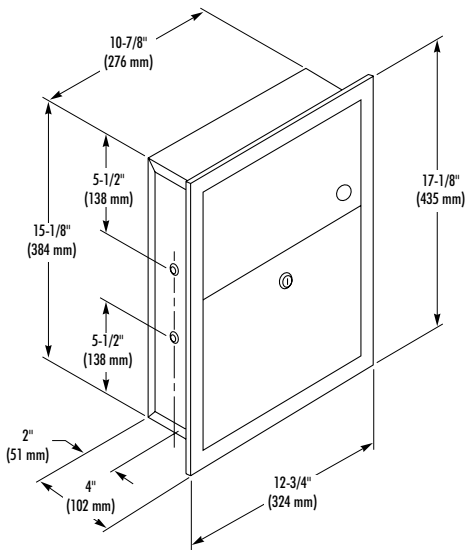

## CONSTRUCTION:

- **FLANGE** fabricated of type 304 (18-8), 22 gauge stainless steel with exposed surfaces in architectural satin finish. One piece seamless construction, 1" wide with 1/4" return.
- **CABINET** fabricated of type 304 (18-8), heavy gauge stainless steel. All welded construction.
- **PUSH FLAP DOOR** fabricated of type 304 (18-8), 22 gauge stainless steel with exposed surfaces in architectural satin finish. Heavy duty stainless steel piano hinge. Self-closing flap door.
- **WASTE CONTAINER** fabricated of type 304 (18-8), 22 gauge stainless steel with tumbler lock keyed like other Bradley units.

## CAPACITY:

1.5 gal. (.2 cu. ft.)

## OPERATION:

Waste container removable with finger grip. Furnished with waxed paper liner. Additional liners available from Bradley.

## INSTALLATION:

Requires rough wall opening 11-3/8"W x 15-3/8"H x 4"D. Top of wall opening 2'-9" above finished floor. Secure to framing with mounting screws (included) at holes provided. Shim at screw points as required.

## GUIDE SPECIFICATION:

Recessed napkin disposal shall be fabricated of type 304 (18-8), stainless steel with exposed surfaces in satin finish. Self-closing push flap door secured by piano hinge. Removable stainless steel receptacle with tumbler lock.

Overall dimensions: 12-3/4"W x 17-1/8"H x 4"D.

**Recessed Napkin Disposal shall be Bradley Model 4731-15.**