

NAPKIN DISPOSAL

- Semi-recessed
- Single End Compartment

Bradex™

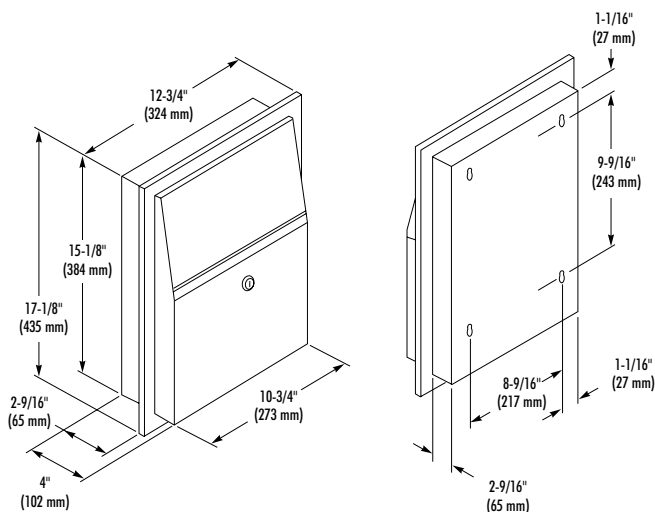

CONSTRUCTION:

- **FLANGE** fabricated of type 304 (18-8), 22 gauge stainless steel with exposed surfaces in architectural satin finish. One piece seamless construction, 1" wide with 1/4" return.
- **CABINET** fabricated of type 304 (18-8), 22 gauge stainless steel. All welded construction.
- **PUSH FLAP DOOR** fabricated of type 304 (18-8), 22 gauge stainless steel with exposed surfaces in architectural satin finish. Heavy duty stainless steel piano hinge. Self-closing flap door.
- **WASTE CONTAINER** fabricated of type 304 (18-8), 22 gauge stainless steel with tumbler locks keyed like other Bradley units.

CAPACITY:

1.5 gal. (.2 cu. ft.)

OPERATION:

Waste container removable from one side with finger grip. Furnished with waxed paper liner. Additional liners available from Bradley.

INSTALLATION:

Requires partition opening 11"W x 15-3/8"H x 2-1/2"D. Top of wall opening 2'-9" above finished floor. Secure unit to framing with mounting screws (included) at holes provided. Shim at screw points as required.

GUIDE SPECIFICATION:

Semi-recessed napkin disposal shall be fabricated of type 304 (18-8), 22 gauge stainless steel with exposed surfaces in satin finish. Self-closing push flap door and removable stainless steel receptacle with tumbler lock.

Overall dimensions: 12-3/4"W x 17-1/8"H x 4"D.

Semi-recessed Napkin Disposal shall be Bradley Model 4722-10-15.