

GREAT VALUE, STYLE, AND FUNCTION.



CLASSIC VERTICAL 100-EV-BP

- Durable and bacteria resistant
- ADA and ANSI compliant when properly installed
- Supports 150 lbs
- Made in the USA
- Easy-to-clean safety strap that adjusts with one hand
- Limited 5 year warranty
- Includes EZ Mount™ backer plate
- True one person installation

 **Foundations®**

BABY CHANGERS MADE BY BABY EXPERTS.™

5216 Portside Dr • Medina, OH 44256, U.S.A.
Public Washroom Sales Manager

Distributed by
www.Ameraproducts.com
Phone: (800) 608-6568
Fax: (409) 840-5545
info@ameraproducts.com



Foundations
BABY CHANGERS MADE BY BABY EXPERTS.™

Submittal Sheet

Model 100-EV-BP Vertical Diaper Changing Station with EZ Mount™ Backer Plate

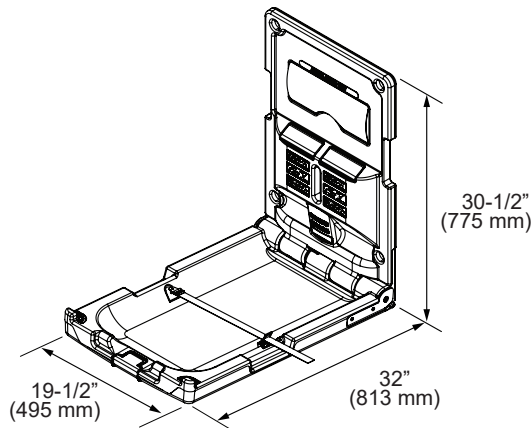

Recommended Blocking

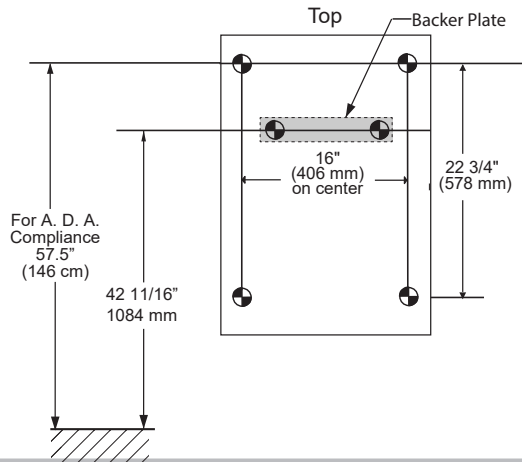

Short Specifications

Polyethylene Diaper Changing Stations:

1. Acceptable product: Foundations Worldwide, Inc.; Model 100-EV-BP.
2. Characteristics:
 - a. Type: Molded FDA approved high-density polyethylene (HDPE) body.
 - b. EZ Mount™ Backer Plate eliminates need for structural backing.
 - c. Child protection strap featuring cam-buckle which is adjustable with one hand.
 - d. Smooth nylon belt with Thermoplastic Polyurethane coating. Easy to sanitize and adjustable with one hand.
 - e. Warning labels printed in English, Spanish and French.
 - f. Meets ASTM F2285 requirements for weight bearing Commercial Changing Stations.
3. A.D.A. Compliance:



- 306.3 Knee Clearance
 - 307.2 Maximum Protruding Objects
 - 308.2 Forward Reach
 - 308.3 Side Reach
 - 309.4 Operation
 - 902.3 Work Surface
- Compliant when properly installed.

4. ANSI compliant safety labels.
5. CPSIA compliant to applicable sections.

- Exclusive EZ Mount™ Backer Plate reduces installation time and enables unit to be attached to wall with only one installer. Also facilitates difficult and retrofit installations by eliminating the need for structural blocking and ensuring connection with two studs.
- Easy to clean, high-density polyethylene which is naturally bacteria resistant.
- Standard with molded-in dual liner dispensers.
- Each liner dispenser holds approximately 50 of the 036-LCR or 036-NWL liners.
- A.D.A. cam-buckle is adjustable with one hand.
- Smooth nylon belt with Thermoplastic Polyurethane coating. Easy to sanitize and adjustable with one hand.
- Convenient bag hooks clearly labeled on both sides
- Easy to read ANSI compliant labels (ANSI Z535.3 and ANSI Z535.4), utilizing universal safety symbols.
- Compact, slim profile meets A.D.A. when properly installed. Only protrudes 4 inches or 102 mm from wall.
- Includes universal changing station door sign.
- Pneumatic gas shock mechanism to ensure smooth, safe open and close motions.
- Steel-to-steel support hinges.
- Includes easy to install, step-by-step instructions plus all mounting hardware.
- ASTM G21 Anti-Bacterial: No measurable bacterial growth.
- Meets or exceeds ASTM F2285 Safety Specifications for Commercial Changing Stations.
- Standard pack: 1 unit.
- Limited Warranty: This product is warranted against manufacturing defects for a period of 5 years.

Installation Information

- Closed unit projects less than 4 inches (101 mm) from wall.
- Open changing surface projects 32 inches (813 mm) from wall during use.
- Overall closed dimensions are 19.5 inches (495 mm) wide and 32 inches (813 mm) tall.
- Hardware allows for mounting to current or new construction applications.

Distributed by
www.AmeraProducts.com
 Phone: (800) 608-6568
 Fax: (409) 840-5545
info@ameraproducts.com