



Oak Fire Extinguisher Cabinets

Detail & Submittal Sheet

Wooden Mallet's new surface mount fire extinguisher cabinet allows you to hide an unsightly extinguisher in plain sight for safety.

- These high quality cabinets are constructed with 3/4" solid oak sides and doors sealed in a durable state-of-the-art finish.
- Cabinet door features contemporary engraving or an acrylic window pane.
- Easily accommodates most 10 lb. fire extinguishers.
- Cabinet is available in three designer colors to coordinate with any décor - light oak, medium oak or mahogany.
- Cabinets are fully assembled and complete with heavy duty hardware for simple wall mounting. All Wooden Mallet products are warranted for one year against defects in materials and workmanship.
- Made in the USA.

Project: _____

Specification Reference: _____

Model Number: _____ Qty: _____

Architect: _____

Contractor: _____

Distributor: _____

Approved by: _____

Date: _____

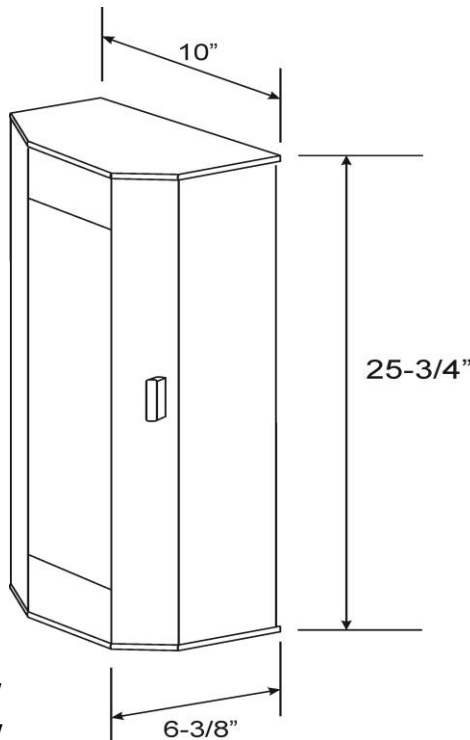

(4) 3/16" HOLES FOR MOUNTING

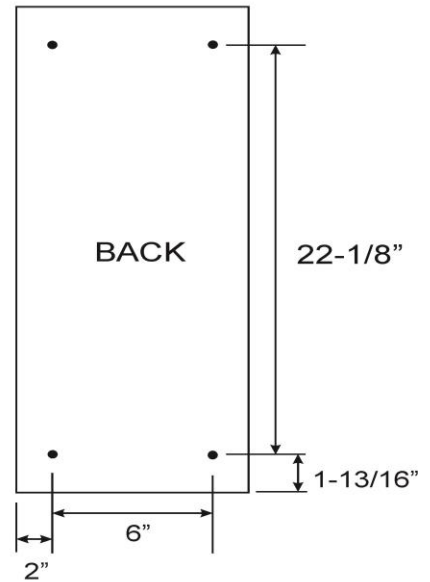

MODEL OPTIONS:

- FEC20LO – Light Oak/Engraved
- FEC20MH – Mahogany/Engraved
- FEC20MO – Medium Oak/Engraved
- FEC21LO – Light Oak/Acrylic Window
- FEC21MH – Light Oak/Acrylic Window
- FEC21MO – Light Oak/Acrylic Window

Specs	Width	Height	Depth	Weight			
Cabinet	10"	25 3/4"	6 3/8"	10 lbs.			
Inside Dimensions	8"	24 1/4"	5 1/4"				
Shipping Carton	Length	Width	Depth	Weight	Dim Weight	Freight Class	Cubic Feet
	28"	11"	7"	13 lbs.	13 lbs.	92.5	1.1

