

ROOF HATCH- Diamond Series™ RHDG Steel

Distributed by
www.Ameraproducts.com
 Phone: (800) 608-6568
 Fax: (409) 840-5545
 info@ameraproducts.com

Ladder Access Hatch

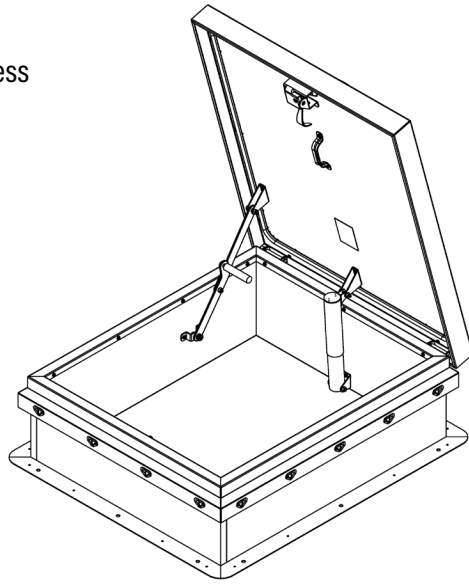

Stair Access Hatch

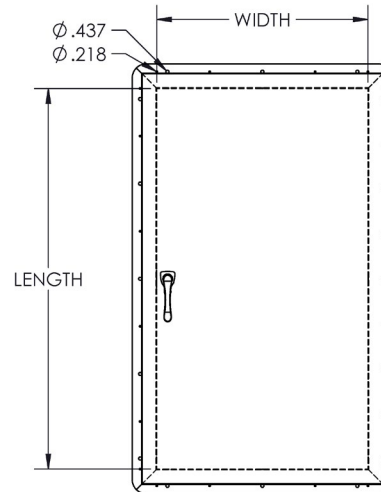
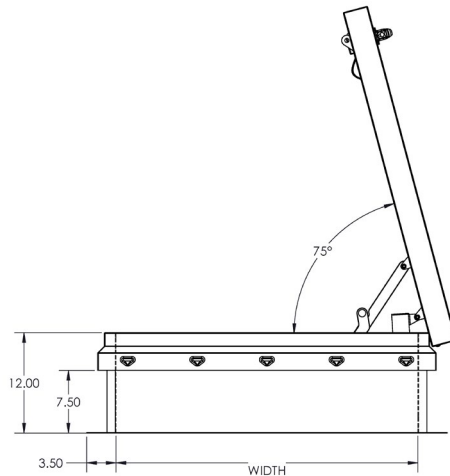
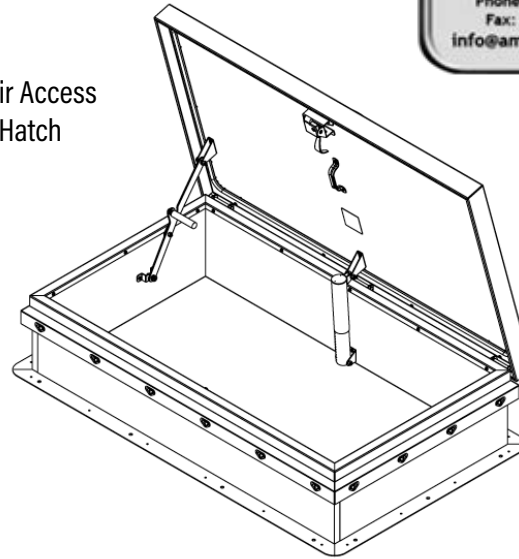

SPECIFICATIONS:

- (1) Curb: Single wall curb and counterflashing with Diamond Grip to secure roof membrane without tools.
 - 14 gauge galvanized steel, white textured powder coat paint
- (2) Cover: Formed and welded with liner, tested to support a live load of 40psf.
 - 14 gauge with 22 gauge liner galvanized steel, white textured powder coat paint
- (3) Gasket: Continuous, weatherproof EPDM sponge rubber adhesive-backed seal.
- (4) Insulation: 1" polyisocyanurate in curb and cover with thermal resistance R-6.
- (5) Spring: Counterbalanced compression springs contained in clear zinc-plated steel cylinders.
- (6) Latch: Clear zinc-plated steel slam latch with inside and outside handles and padlock hasps. Tested to 50psf wind uplift.
- (7) Hold Open Arm: Clear zinc-plated automatic locking hold open arm with red vinyl grip for one handed door operation.
- (8) Hinge: Heavy duty clear zinc-plated steel pintle hinge.

Notes: For pitched roofs up to 7:12, mount hinge side parallel to slope. Door opens 75°.

Min Size: 24" X 24" | Max Size: 48" X 96"

Diamond Series™ is a trademark of Activar Construction Products Group, Inc.

QTY	SIZE W x L	STEEL	TYPE
	36" x 30"	<input type="checkbox"/> RHDG-1WT	LADDER
	30" x 54"	<input type="checkbox"/> RHDG-2WT	STAIR
	30" x 96"	<input type="checkbox"/> RHDG-3WT	STAIR
	36" x 36"	<input type="checkbox"/> RHDG-4WT	LADDER
	48" x 48"	<input type="checkbox"/> RHDG-5WT	LADDER
	32" x 72"	<input type="checkbox"/> RHDG-6WT	STAIR
	37" x 30"	<input type="checkbox"/> RHDG-7WT	LADDER
		<input type="checkbox"/> STEEL	

Custom sizes available - enter size above

FEATURES AT ADDITIONAL COST:

- ___ Gray Textured Finish (GT)
- ___ R-9, 1.5 Polyiso Curb (IP)
- ___ Curb Double Wall (CD)
- ___ Stainless Hardware (SS)
- ___ Red Textured Finish (RT)
- ___ 3/4" Wood Nailer (IW)
- ___ Curb Heights from 13" to 22" ___ (H13-H22)
- ___ Steel Curb, Aluminum Cover (AL)
- ___ Bronze Textured Finish (BT)
- ___ 1" Fiberboard (IF)
- ___ Stainless 316 Hinge Pin (SP)



9702 Newton Ave S. Bloomington, MN 55431 | Many Locations Nationwide

Distributor:		Project:
Contractor:		Approved By:
Date:	Quantity:	Architect:
Scale: N/A	Pages: 1 of 1	Drawing #: