

ROOF HATCH - Diamond Series™ - ROOF HATCH, DIAMOND SERIES 30 X 54 (RHG-2) | GALV STEEL, WHITE TEXTURED

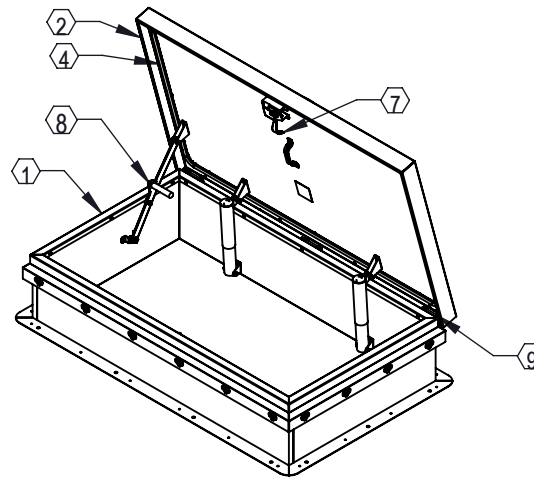
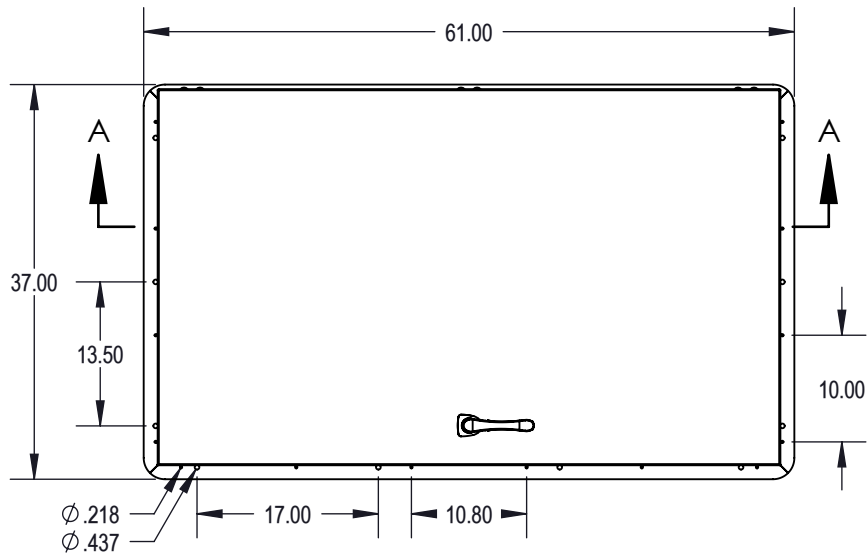

SPECIFICATIONS:

1. Curb: 14 gauge galvanized steel single wall curb and counterflashing with Diamond Grip.
2. Cover: 14 gauge galvanized steel formed, welded cover with 22 gauge liner, tested to support a live load of 40psf.
3. Finish: White, textured powder coat paint.
4. Gasket: Continuous, weatherproof EPDM sponge rubber adhesive-backed seal.
5. Insulation: 1" polyisocyanurate in curb and cover with thermal resistance R-6.
6. Spring: Counterbalanced compression springs contained in clear zinc-plated steel cylinders.
7. Latch: Clear zinc-plated steel slam latch with inside and outside handles and padlock hasps. Tested to 50psf wind uplift.
8. Hold Open Arm: Clear zinc-plated automatic locking hold open arm with red vinyl grip for one handed door operation.
9. Hinge: Heavy duty clear zinc-plated steel pintle hinge.

Notes:

For pitched roofs up to 7:12, mount hinge side parallel to slope.
 Door opens 75°
 Clear Opening: 19" X 48"
 Weight: 187lbs

Diamond Series™ is a trademark of ACPG.

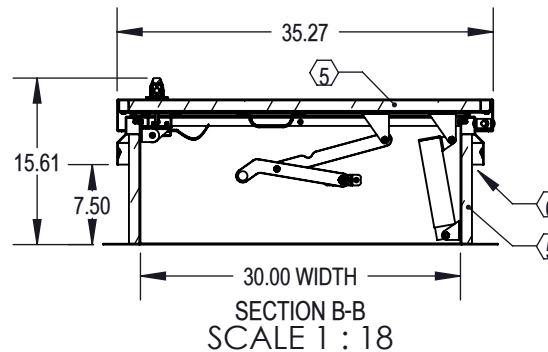
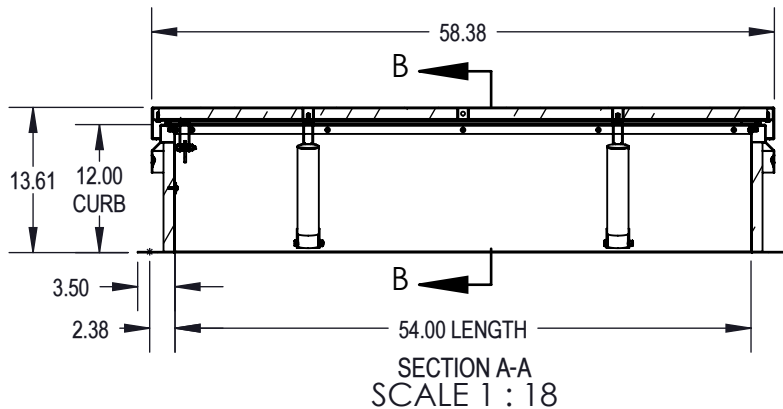

MODEL #: RHDG-2WT



| | | |
|--------------|---------------|---------------------------------|
| Distributor: | | Project: |
| Contractor: | | Approved By: |
| Date: | Quantity: | Architect: |
| Scale: 1:16 | Pages: 1 OF 1 | Drawing #: RHDG-2WT-SUBMITTAL_A |