

FLOOR DOOR - ANGLED FLOOR DOOR - FLDA

A flush floor door that is designed to remain corrosion-free with non-slip diamond plate surface.

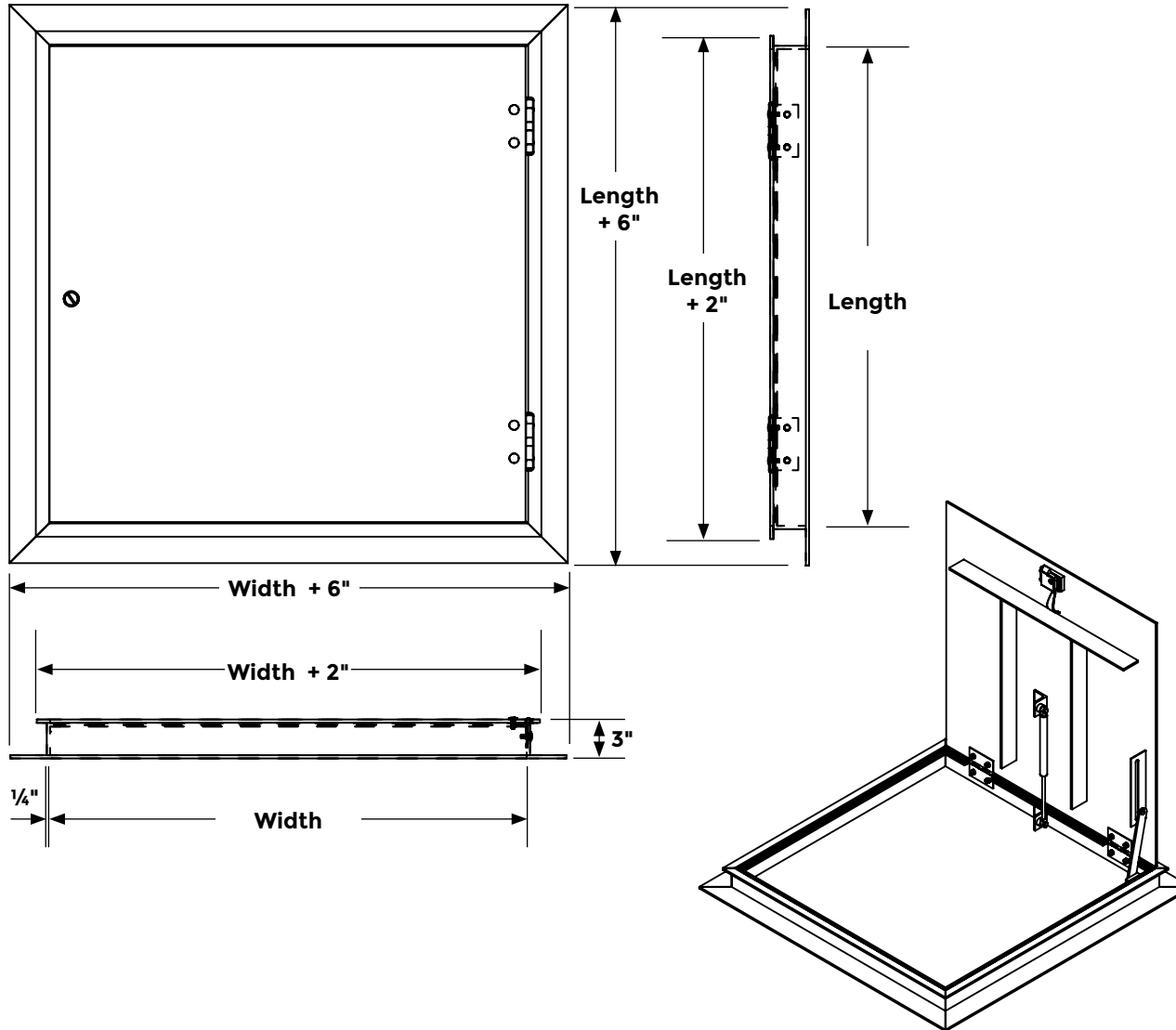

SPECIFICATIONS:

Frame Material: 1/4" extruded aluminum

Door Material: Reinforced 1/4" diamond aluminum plate.

Standard Finish: Mill with bituminous coating on outer frame

Latch: 304 Stainless steel slam latch with flush key operator on exterior and handle opener on inside. Removable stainless 18-8 threaded plug and 5/16" steel square key included.

Hinge: 304 Stainless steel

Spring: 304 Stainless steel gas assist opener

Hold Open Arm: Stainless steel automatically locks door open

Hardware: 18-8 Stainless steel bolts, nuts and washers

Load: 300 psf

Sizes: Minimum 24" x 24", Maximum 60" x 60"

ORDER SIZE = FRAME INSIDE DIMENSION

QTY	MODEL	ORDER SIZE		DOORS	APPROX. WEIGHT
		WIDTH	LENGTH		
	FLDA-2424S	24"	24"	Single	60
	FLDA-2436S	24"	36"	Single	76
	FLDA-3030S	30"	30"	Single	81
	FLDA-3048S	30"	48"	Single	115
	FLDA-3636S	36"	36"	Single	100
	FLDA-3648S	36"	48"	Single	118
	FLDA-3730S	37"	30"	Single	92
	FLDA-4242S	42"	42"	Single	120
	FLDA-4848S	48"	48"	Single	145

	FLDA-4848D	48"	48"	Double	154
	FLDA-6060D	60"	60"	Double	215

Custom Size					
-------------	--	--	--	--	--

ADDITIONAL OPTIONS

Padlock Tab - PT



Distributor:

Project:

Contractor:

Approved By:

Date:

Architect:

Scale: N/A

Pages: 1 of 2

Item #:

FLOOR DOOR - ANGLED FLOOR DOOR - FLDA

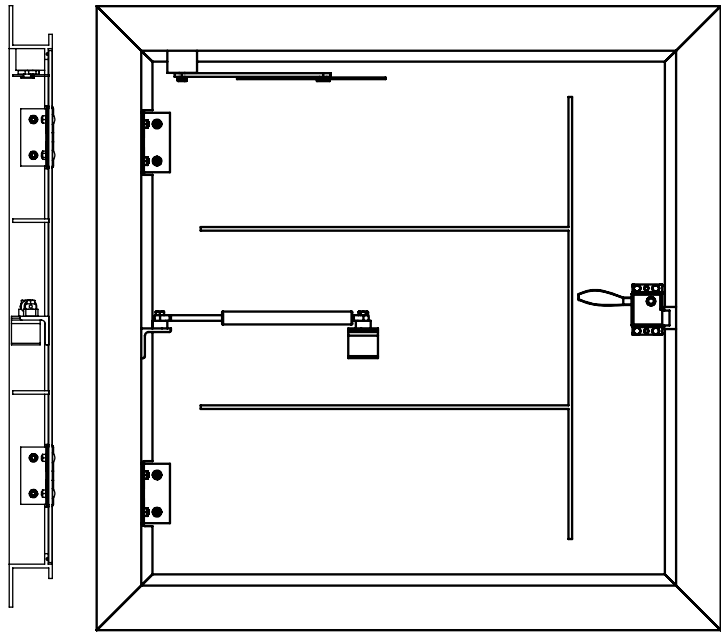

Single Door

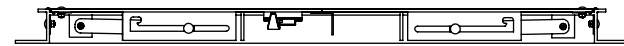
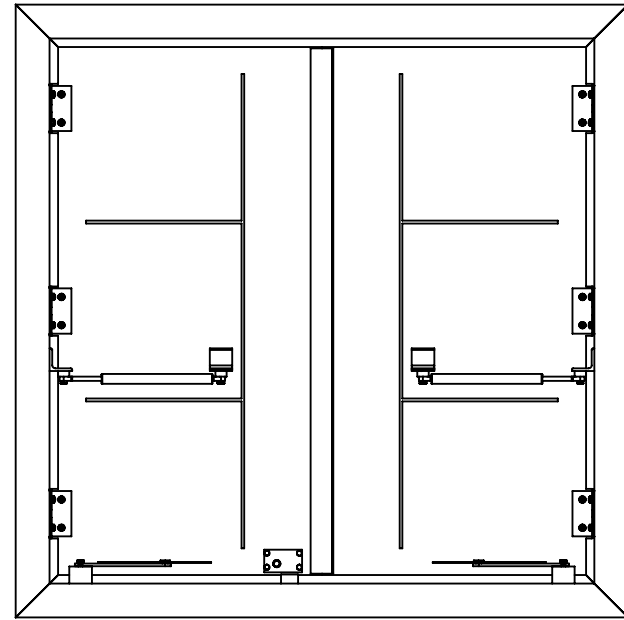

Double Door

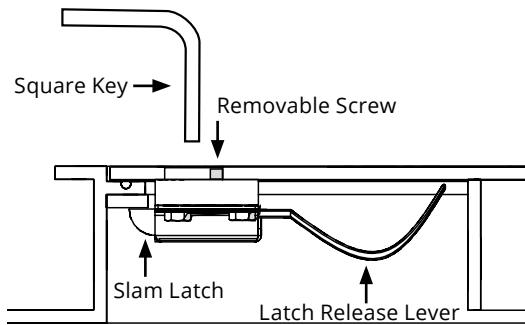

Latch Detail

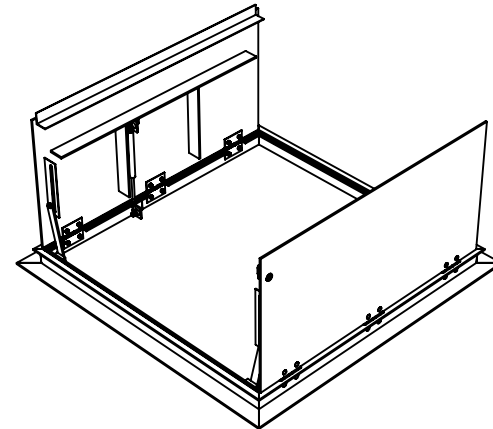

Distributor:		Project:
Contractor:		Approved By:
Date:		Architect:
Scale: N/A	Pages: 2 of 2	Item #: