

CRP / DKS LOUVERS

TYPE: VLV Louvers

INSTALLATION INSTRUCTIONS

1. Prior to installation read and follow all door manufacturer's instructions and requirements for application of the louver kit. Instructions may vary between different types and size of application.
2. Cut receiving hole in the door corresponding to the order size of the louver. Make certain the cut out is square in the door.
3. Insert the corridor side (outside) of the louver into the opening. Use shim material if necessary to square the unit.
4. Insert the inside louver side into the cut out. Align pre-drilled holes then tighten using the screws provided.
5. Tighten the screws in cross pattern to obtain even pressure on the frames, while making the louver square and aligned to the door.

Warnock Hersey

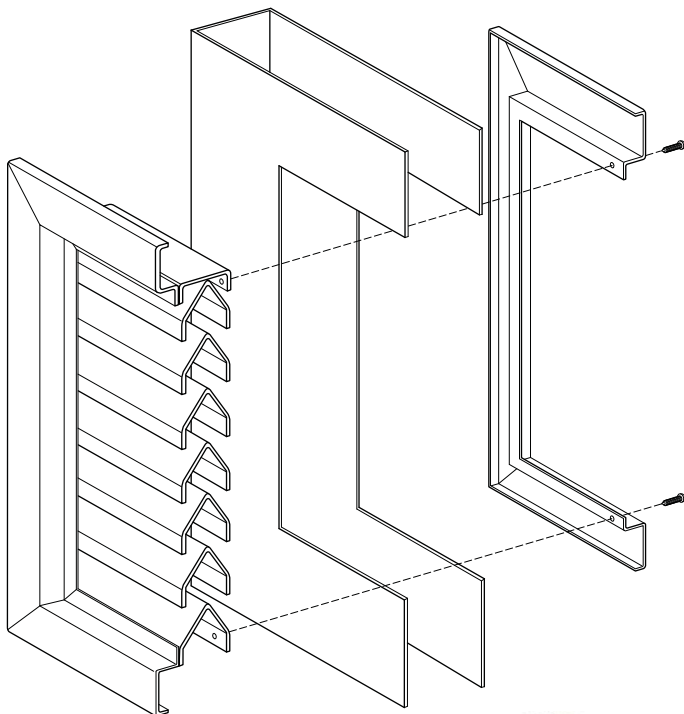

Distributed by
www.Ameraproducts.com
Phone: (800) 608-6548
Fax: (409) 840-5542
info@ameraproducts.com