



Distributed by  
www.Ameraproducts.com  
Phone: (800) 608-6548  
Fax: (409) 840-3040  
info@ameraproducts.com

MODEL №: 3800-W

ISSUED: 12/09

REVISED:

**1-1/2" DIA (Ø38) SERIES GRAB BAR WITH WHITE POWDER COATED FINISH**

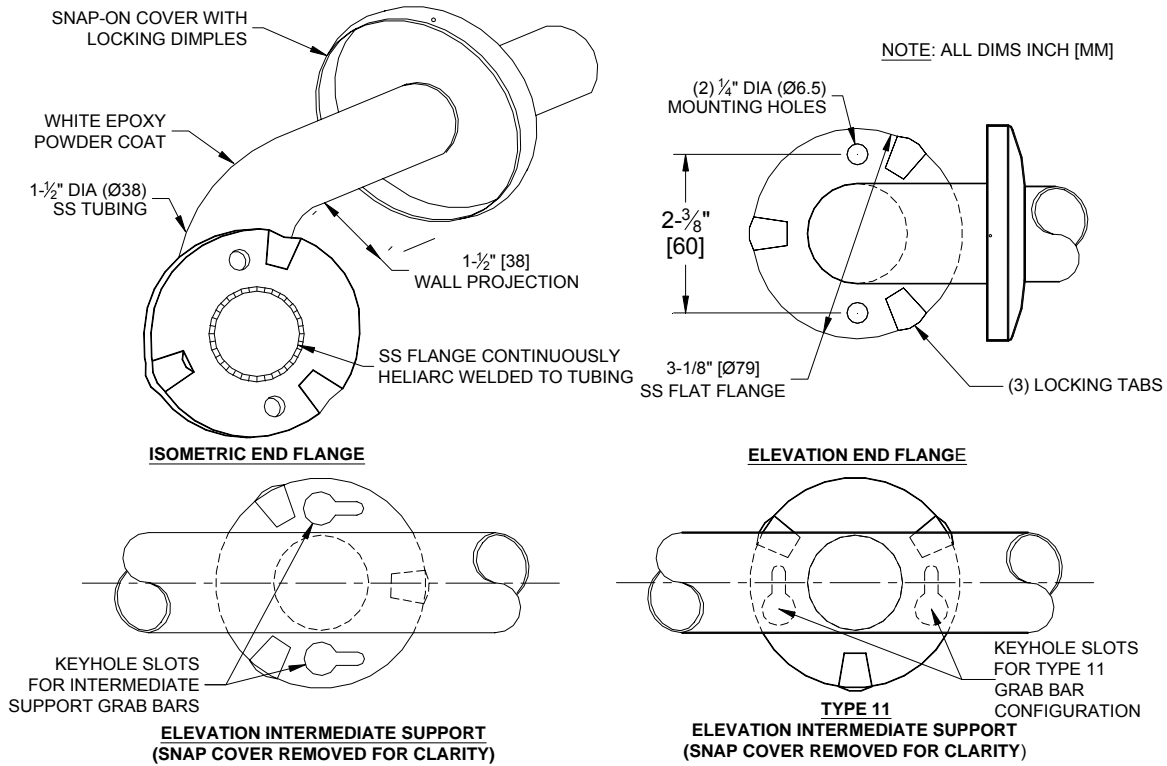

Model №	Width	Qty	Model №	Width	Qty
3801-18W	18" [457]		3801-36W	36" [914]	
3801-24W	24" [610]		3801-42W	42" [1067]	
3801-30W	30" [762]		3801-48W	48" [1219]	

**SPECIFICATION**

White Grab Bar with Snap-On Flange Covers for concealed mounting shall be type 304 stainless steel alloy 18-8. Tubing shall be 1-1/2" diameter (Ø38) x 18 gauge [0.048"] (1.2). Snap-on cover shall be 21 gauge [0.035"] (0.9). Flange shall be 5/64" (2) thick and shall be Heliarc welded to tubing with a continuous concealed bead. End flanges shall have two (2) 1/4" diameter (Ø6) mounting holes on 2-3/8" diameter (Ø61) bolt circle. Center posts (if any) shall have (2) keyhole slots to ease installation access. Available standard sizes are in the -01 configuration only as per schedule above. All exposed surfaces shall have a white epoxy powder coated finish and shall be protected during shipment with a plastic bag.

**White 1-1/2" Diameter (Ø38) Grab bar with Snap-On Flange Covers shall be Series № 3800-W of American Specialties, Inc., 441 Saw Mill River Road, Yonkers, New York 10701- 4913**

**STRENGTH**

ASI Grab Bars are designed to meet and exceed ADA requirements as published in CABO/ANSI A117.1-2003 and CFR 28 Part 36, 1 July 1994, section 4.26.3 and FAB-ADA-ABA Regulations of 23 July 2004 Section 609. Mounting to the wall is a critical part of the system to meet this requirement. To withstand the shear, tension or pullout, and torsion loads generated by the maximum loading, the fastener system must be adequately sized.

**INSTALLATION**

Use grab bar as template to mark mounting holes locations and pre-drill holes. Install bar using two (2) № 10 self-tapping pan head screws and flat washers (by others) or other fastener system (by others) to suit conditions for each flange. Appropriate anchoring and backing must be provided in accordance with local building codes or as specified on Architects Plans prior to wall finishing. For compliance with ADA Accessibility Guidelines install unit so that the top of the grab bar is 33" (840) minimum above finished floor (AFF) to 36" (915) maximum AFF. Anchors are available from ASI and must be specified separately for each grab bar style scheduled (see 3900 series).

Accessory Specialties

AMERICAN DISPENSER

Desert Ray Products

WATROLS, INC.