



AMERICAN SPECIALTIES, INC.  
441 Saw Mill River Road, Yonkers, NY 10701

MODEL No: 0605

ISSUED: 01/87

REVISED: 7 NOV 2014

## INTER-LOK STAINLESS STEEL MIRROR WITH SHELF

Distributed by  
[www.Ameraproducts.com](http://www.Ameraproducts.com)  
Phone: (800) 608-6568  
Fax: (409) 840-5545  
info@ameraproducts.com

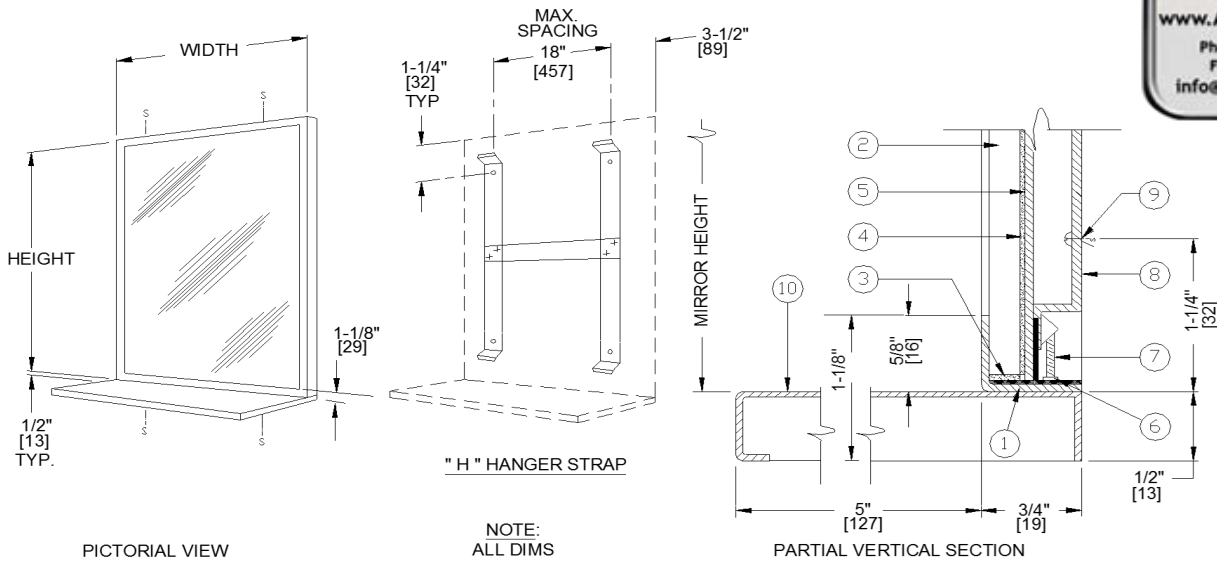

NOTE:  
ALL DIMS  
INCH [MM]

- DESCRIPTION
1. 18 GAUGE STAINLESS STEEL FRAME
  2. 1/4" [6] PLATE GLASS MIRROR
  3. SHOCK-ABSORBING EDGE CUSHION
  4. NON-ABSORBENT FILLER
  5. 20 GAUGE CORROSION PROTECTED STEEL BACK

6. MOUNTING NUT
7. TAMPER-PROOF MOUNTING & LOCKING SCREW 10-32 X 1-1/4" [32mm]
8. HANGER BRACKET- 18 GAUGE
9. INSTALLATION SCREW-FURNISHED BY INSTALLER
10. STAINLESS STEEL SHELF 18 GAUGE

### SPECIFICATION

Inter-Lok Stainless Steel Framed Mirror with Shelf shall be fabricated of alloy 18-8 stainless steel, type 304, 18 gauge with mitered corners welded and polished. Structural reinforcement gussets shall be of welded construction. Mirror glazing shall be \_\_\_\_\_ (insert glazing option) and shall be warranted for 15 years against silver spoilage. All edges of mirror shall be protected with friction and chafe absorbing fillers. Back of mirror shall be protected by full size shock-absorbing water-resistant filler and full size one piece 20 gauge corrosion protected steel. An 18 gauge corrosion protected steel "H" bracket shall be supplied. Mirror shall be secured to vertical brackets with corrosion protected allen head locking screws furnished. All exposed surfaces shall be N<sup>o</sup> 4 satin finish.

**Inter-Lok Stainless Steel Framed Mirror shall be Model N<sup>o</sup> 0605-\_\_\_\_\_ (insert glazing option) \_\_\_\_\_ (note size W x H) as manufactured by American Specialties, Inc., 441 Saw Mill River Road, Yonkers, New York 10701-4913.**

### MATERIALS

- Frame:** 18-8, type 304, 18 gauge (.048 in. <1.2mm> thick) stainless steel. Unitized all welded construction. Corners mitered, welded and polished. Exposed surfaces have N<sup>o</sup> 4 satin finish. Edges and corners are burr free.
- Shelf:** 18-8, type 304, 18 gauge (.048 in. <1.2mm> thick) stainless steel. Unitized all welded construction. Exposed surfaces have satin finish. Edges and corners are burr free.
- Glass:** Standard glazing is N<sup>o</sup> 1 quality, 1/4" inch (6.4mm) thick plate/float, silver coated and hermetically Sealed with a uniform coating of electrolytic copper plating, warranted against silver spoilage for 15 years. Mirrors meet Federal Spec. DD-M-411C, ASTM C-1503, and ASTM C-1036-91.
- Filler:** Expanded polyethylene microcell foam sheet material, abrasion resistant and shock absorbing, water resistant, 1/8" inch (3.2mm) total layer thickness.

### INSTALLATION

Install brackets level and plumb per diagram location using N<sup>o</sup>10 self tapping screws (by others). Hang mirror on brackets and tighten locking screws provided at top & bottom. For ADA compliance, bottom edge of reflecting surface should be no higher than 40" (1016mm) above finished floor.

### GLAZING OPTIONS

Units are supplied with 1/4" thick plate glass. Other glazing options are available. For a complete description of any other available glazing, see the MIRROR GLAZING OPTIONS chart.

Accessory Specialties

AMERICAN DISPENSER

Desert Ray Products

WATROLS INC.