

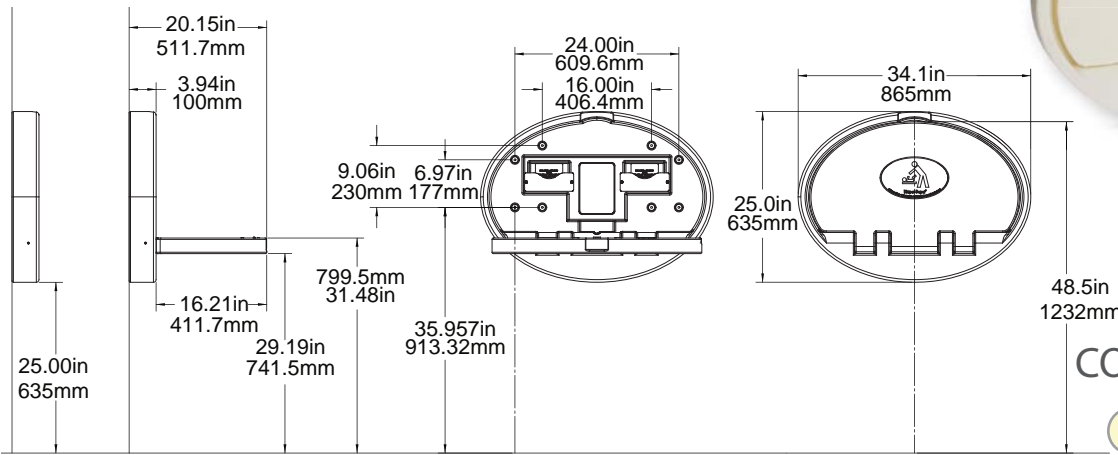

DIAPER-DEPOT[®]

OVAL BABY CHANGING STATION



COLORS AVAILABLE

-  Ivory
-  Powder Gray
-  White
-  Speckled Gray

Specification:

Specification: Unit should meet ASTM F2285 Consumer Safety Performance Standards for Commercial Diaper Changing Stations. Unit should be constructed from high-density polyethylene, which prohibits the retention of moisture and odors. Reinforced steel rods increase unit stability. Gas shocks should be completely hidden for safer bed retraction preventing injuries to hands and fingers. Products should be suitable for processing by any approved recycling facility. Unit should be manufactured with FDA approved plastic (FDA 21 CFR 177.1520 (c) 3.1). Unit should be provided with a self-adhesive sign for installation on restroom door. Unit should be provided in numerous color choices to accent building's internal décor. Unit should be Oval in design. Unit should be provided equipped with a genuine Safe-Strap® safety belt. Unit should contain a concave changing surface to ensure child's comfort and protection. Units should contain dual dispensers for bed liners. Instructions should contain full color universal characters and written in English, German, French and Spanish to facilitate multilingual understanding, contrasting in color and be permanently molded into unit to prevent peeling, fading or vandalism. The date of manufacture should be molded into the unit and remain visible after installation. Unit should contain a manufacturer's item number and it should remain visible after installation. Unit should protrude no more than 4" from the wall in its closed position and less than 20" when fully open.

Unit should be adaptable to 16" stud wall construction with punch-out predrilled holes. Unit should be equipped with a molded-in diaper bag hook. Unit should be provided with the necessary hardware to install on most wall types. Design should allow for easy passage around unit and contain no sharp corners to injure customers. Unit should comply with the following ADA Accessibility Guidelines when applicable and installed to the manufacturer's specifications: 4.4.1 Protruding Objects, 4.2.5 Forward Reach, 4.2.6 Side Reach, 4.23.3 and 4.23.7 Fixtures, 4.32.3 Knee Clearances at Counter and 4.32.4 Height of Counters. Unit should comply with ADA 4.27.4 Operation with One Hand or Closed Fist.

The illustrations and descriptions herein are applicable to production as of the date of this Cut Sheet. The manufacturer reserves the right to, and does from time to time, make changes and improvements in designs and dimensions.

The world of retail can be a complicated place. At Safestrap™ we are committed to simplifying it.

Corporate Office
SAFESTRAP COMPANY, INC.
105 West Dewey Avenue, Building D
Suite 410, Wharton, NJ 07885

Distributed by
www.Ameraproducts.com
Phone: (800) 608-6568
Fax: (409) 840-5545
info@ameraproducts.com